



CM



CM1 - CM2 - CM3 - CM4

Cakmak Crane Inc.
www.cmak.com
sales@cmak.com





Welcome to **the** Technology



With continuously wide research and development, CM series were formed on robust and high-quality design that ensure high reliability and endurance. Lift the standards up with CM series.

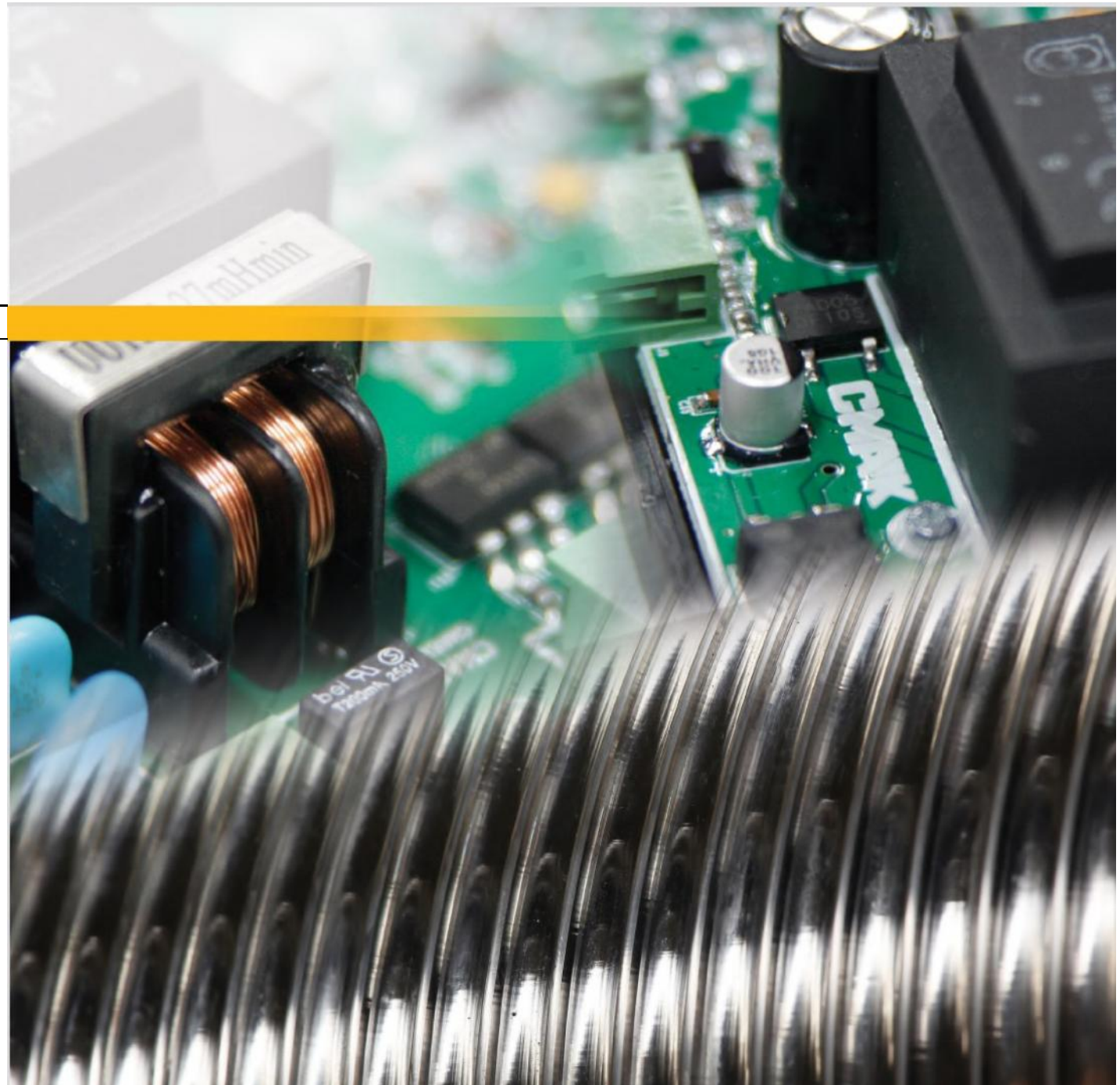



Advantages
Technical Specification
HoistSense
Crane Kits

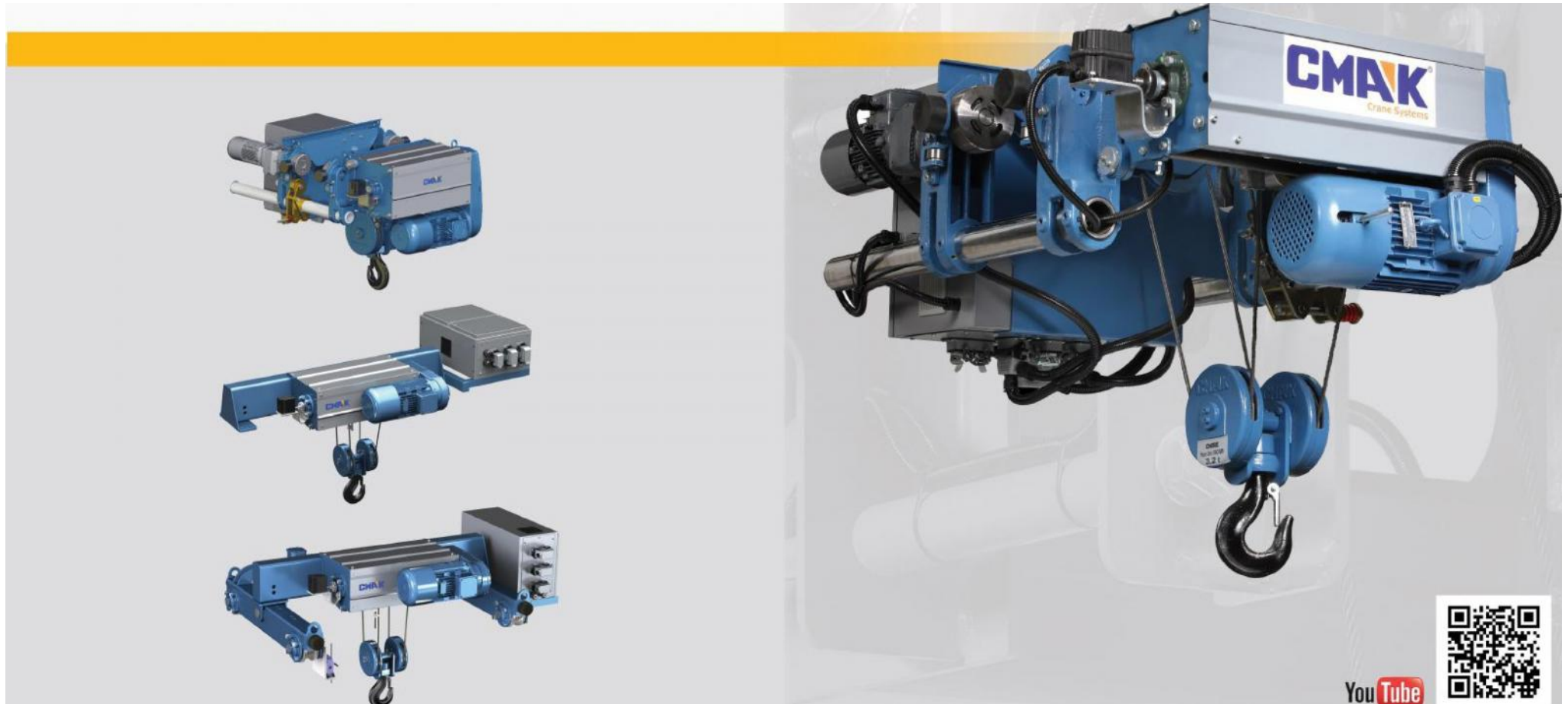



Robust Design

EASY MAINTENANCE

With welded construction and chassis, CM series electric wire rope hoists have long service life. Electrical parts of the CM series electric wire rope hoists can be easily disassembled for maintenance or another electrical module can be integrated easily. CM hoists, in terms of electrical systems, are designed "plug/remove" principle.



Long Service Life

HOIST PROTECTION SYSTEM

CM series high-technology electric wire rope hoists are equipped with PTC, Termc, Phase Safe-Guard, Emergency Systems, Top and Bottom Limiters and overload limiters. Also, CM series electric wire rope hoists are compatible with the FEM and CE norms. Thus, they are very reliable and safely operational.



Minimum Maintenance Requirement

LONG SERVICE LIFE

CM series hoists are designed to endure severe conditions for years, also its design lowers the maintenance requirement while reducing your maintenance costs.



Bottom and Top Hook Movement Limiter

DURABLE LIMITS

Top and bottom hook travel limits have levels, and are easily adjustable to ensure trouble-free operation. In case of hook getting close to top or bottom limits, hoisting will get automatically stopped at the extreme limit set. Thus ensures safe and healthy operation.



Safe Operation

EMERGENCY SYSTEM

In an emergency, operator can simply press the emergency stop button, located at the bottom of the pushbutton, to cut the main power of the crane. Also in situation of power surges, CM hoists will automatically cut the main power to avoid its systems getting damaged.



Operator Health First

LOW CONTROL VOLTAGE

CM series electric wire rope hoists' standard control voltage is 48 V. In case of an insulation problem of the pushbutton, only 48 V electricity is on the circuits that are close to the operators hands.





Overload Device
SAFE LOAD LIMITER

CM type electro-mechanical overload device is very reliable and can be easily adjusted with just an allen wrench thus ensures safe operation. With preset values, in case of lifting heavier loads than the nominal load, the lifting operation is stopped immediately to avoid damage to the machinery, system and most importantly your building.

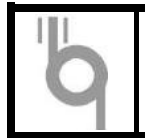

Rope Guide
DURABLE ROPE GUIDE

CM type graphite cast iron rope guides, ensures the wire rope tightly reeved to the drum and its flexibility design minimises the breakage due to wrong usage.



Direct Driven Drives and Articulation
GTYPE TRAVELMECHANISM

Cross-travel mechanisms of the CM series electric wire rope hoists are direct driven and supported with an articulated end carriage points ensuring positive contact of all wheels with the tracks.



Manual Brake Release
MANUAL LOAD LOWERING

CM series electric wire rope hoists' hoisting motor is equipped with manual brake release, thus, in case of unexpected power failures, the loads can be lowered to the ground manually with using the manual brake release.



High Tensile Wire Rope
DURABLE WIRE ROPE

CM series electric wire rope hoists are equipped with high tensile strength steel wire rope. In addition to its high tensile, it is also inexpensive to replace.



High Efficiency
HIGH EFFICIENT LIFTING MOTOR

CM series hoists are capable of operating under heavy conditions with generation 3000rpm output lifting motors.



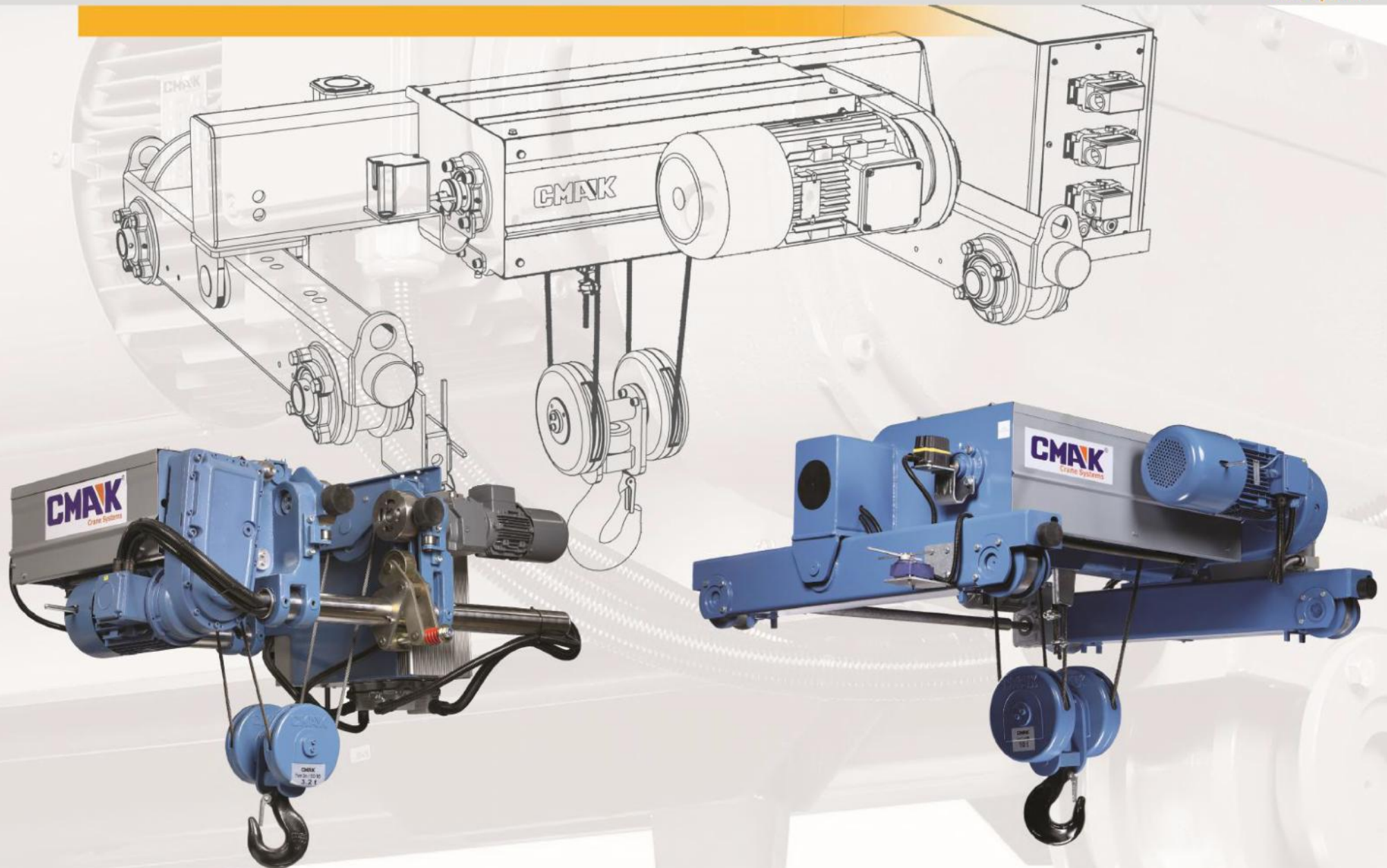

Technical Specification

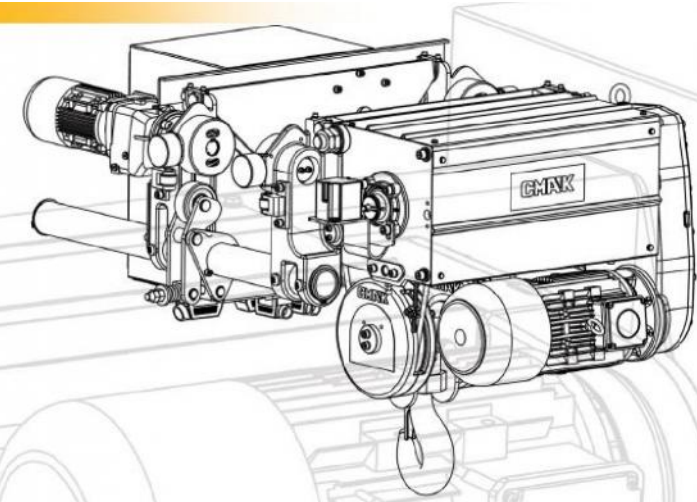
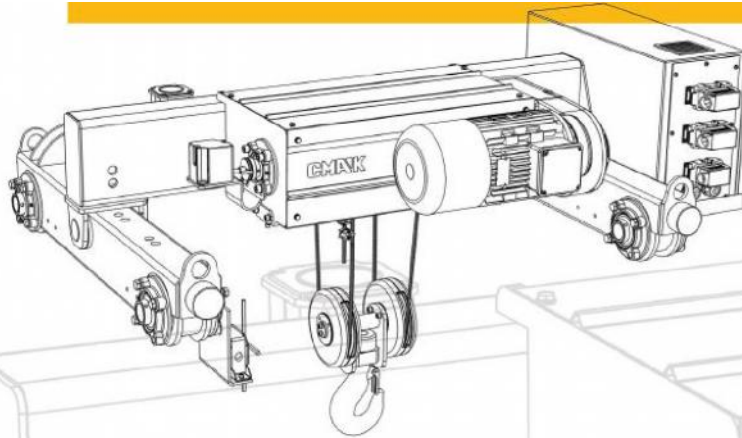

Capacity	Height of Lift	Hoisting Speed		Cross - Travel Speed			FEM	ISO	Type	Trolley Type			
		Slow m/min	Nominal m/min	Slow m/min	Nominal m/min	Ultraspeed m/min				(S)	(M)	(D)	True Vertical Lifting
630	1,0								CM1L4.11.A	•	•	•	•
	J6,0	3,85	1,5,4	16	14		Jm	M6	CM1B6.11.A	•	•	•	•
	4M								CM1L8.11.A	•	•	•	•
800	14,0								CM1H4.11.B	•	•	•	•
	36,0	85	15,4	16	24		2m	M5	CM1L36.11.B	•	•	•	•
	480								CM1L48.11.B	•	•	•	•
1000	12,0								CM1L211.A	•	•	•	•
	11,0	1,92	7,7	16	24		3m	MS	CM1L21.A	•	•	•	•
	2<-0								CM1H42.1.A	•	•	•	•
1250	11,0								CM1H21.B	•	•	•	•
	11,0	1,92	7,7	16	24		Jm	M6	CM1H8.21.B	•	•	•	•
	2,0								CM1H4.11.B	•	•	•	•
1600	12,0								CM1H22.1.C	•	•	•	•
	11,0	1,92	7,7	16	24		2m	M5	CM1H19.1.C	•	•	•	•
	2,0								CM1L24.1.C	•	•	•	•
2000	24,0								CM2L211.A	•	•	•	•
	36,0	2,77	16,6	16	24		1Am	PM	CM2L36.11.A	•	•	•	•
	4M								CM2L49.11.A	•	•	•	•
2500	6,0								CM1L06.41.A	•	•	•	•
	9,0	0,96	3,85	16	24		Jm	M6	CM1L00.41.A	•	•	•	•
	12,0								CM1H1W.A	•	•	•	•
2500	12,0								CP2L12.11.A	•	•	•	•
	11,0	1,4	8,3	16	24		3m	MB	CP2L18.11.A	•	•	•	•
	24,0								CP2L24.11.A	•	•	•	•
2500	6,0								CM1H01.B	•	•	•	•
	9,0	0,96	3,65	16	1*		Jm	MB	CM1L09_41.B	•	•	•	•
	12,0								CM1H11_1.B	•	•	•	•
2500	12,0								CM1H12.21.8	•	•	•	•
	11,0	1,4	8,3	16	1*		2m	M5	CM2H8.21.B	•	•	•	•
	24,0								CP2L24.1,8	•	•	•	•
2500	24,0								CM1H24.11.A	•	•	•	•
	36,0	2,7	18	16	11		2m	111	CM3L36.11.A	•	•	•	•
	49,0								C_1L48.11.A	•	•	•	•

Capacity	Height of Lift	Hoisting Speed		Cross - Travel Speed			FEM	ISO	Type	Trolley Type				
		Slow m/min	Nominal m/min	Slow m/min	Nominal m/min	Ultraspeed m/min				(S)	(M)	(D)	True Vertical Lifting	
3200	6,0								CM1L66.41.C	•	•	•	•	
	9,0	0,96	3,85		16	24	2m	M5	CM1H09.41.C	•	•	•	•	
	12,0								CA'1L1ULC	•	•	•	•	
	12,0								CM2L12.21.C	•	•	•	•	
	11,0	1,4	8,3	16	16	16	1Am	M4	CA'1H18_2.C	•	•	•	•	
	14,0								CM1L24.21.C	•	•	•	•	
	12,0								CM1L24.11.B	•	•	•	•	
	18,0	2,7	16	16	16	16	2	1Am	M4	CM1L13_1S_11.B	•	•	•	•
	14,0								CM1L348.11.B	•	•	•	•	
	*,0								CM1L04.11.A	•	•	•	•	
	6,0	0,64	2,56	16	16	16	1	2m	M5	CM1L06.11.A	•	•	•	•
	6,0									CPM1UL6.1J.	•	•	•	•
3200	6,0								CM2D6-41.A	•	•	•	•	
	9,0	0,7			16	24	Jm	M6	CM2L09<1A	•	•	•	•	
	12,0								CM1L12.41.A	•	•	•	•	
	12,0								CM1L12.11.A	•	•	•	•	
	1ao	1,3			16	2	3m	MS	CM1L18.21.A	•	•	•	•	
	2,0								Ct.13L2WA	•	•	•	•	
	3200	4,0								CM1H13L61.a	•	•	•	•
		6,0	0,64	2,58		16	16	1Am	M4	CM1LD6.11.B	•	•	•	•
		8,0								CM1LOB.61.B	•	•	•	•
		6,0								CM2I06<111	•	•	•	•
		9,0	0,7			16	24	2m	M5	CM2LD9.1.B	•	•	•	•
		11,0								CM1H2.41.B	•	•	•	•
12,0									Ct.13H211.B	•	•	•	•	
18,0		1J			16	14	2m	M5	CP.13H18.21.B	•	•	•	•	
24,0									CM1L24.21.B	•	•	•	•	
24D		24,0								CPM1.24.11.A	•	•	•	•
		36,0	2J	14	16	16	2	2m	M1	CPM1.36.11.A	•	•	•	•
		<11,0								CM1L48.11.A	•	•	•	•

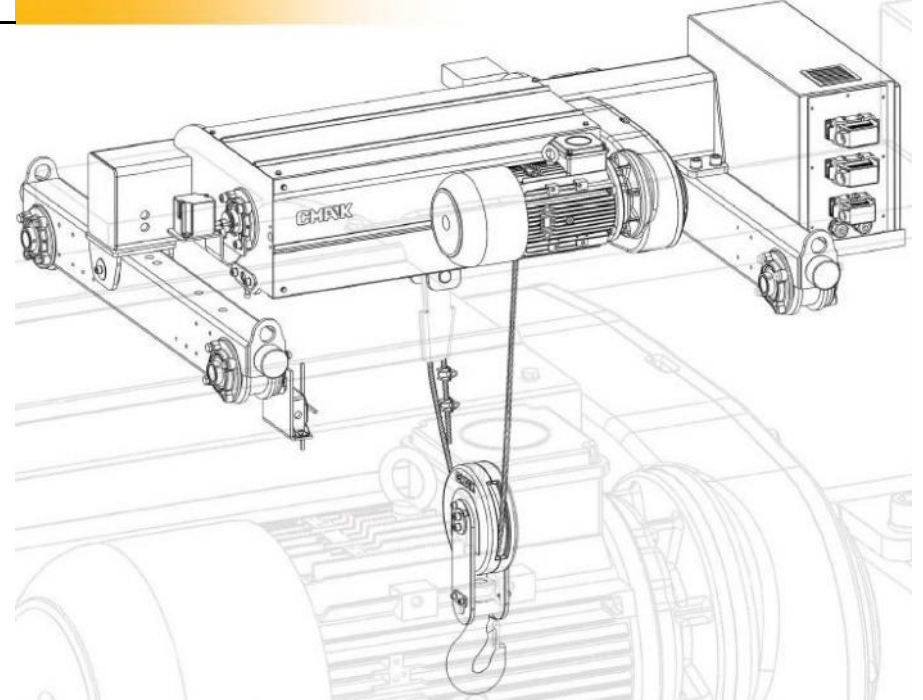
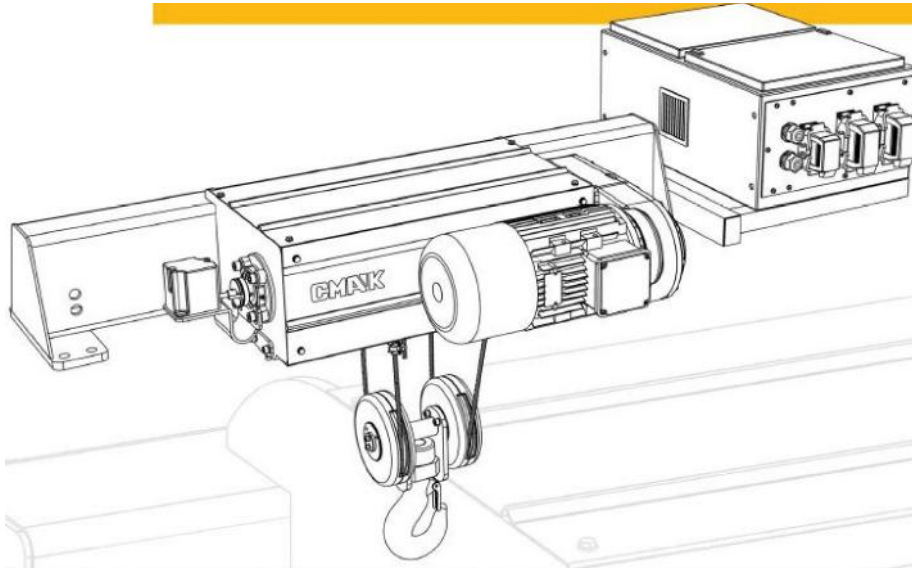

Capacity	Height of Lift	Hoisting Speed	Cross - Travel Speed			FEM	ISO	Trolley Type					
6300	20	0.7	4	16	14	Am	M4	CM1L06.41.C	•	•	•	•	•
	12.0	1.3	6	16	24	1Am	M4	CM1L06.41.C	•	•	•	•	•
	11.0	1.3	14	16	14	1Am	M4	CM1L06.41.C	•	•	•	•	•
8000	4.0	0.6	4	16	24	1Am	M4	CM1L06.41.C	•	•	•	•	•
	2.0	0.6	1.5	4	16	1Am	M4	CM1L06.41.C	•	•	•	•	•
	2.0	0.6	1.5	4	16	1Am	M4	CM1L06.41.C	•	•	•	•	•
	2.0	0.6	1.5	4	16	1Am	M4	CM1L06.41.C	•	•	•	•	•
	2.0	0.6	1.5	4	16	1Am	M4	CM1L06.41.C	•	•	•	•	•
	2.0	0.6	1.5	4	16	1Am	M4	CM1L06.41.C	•	•	•	•	•
10000	2.0	0.6	4	16	24	1m	M4	CM1L06.41.C	•	•	•	•	•
	9.0	0.6	4	16	24	1m	M4	CM1L06.41.C	•	•	•	•	•
	12.0	0.6	4	16	24	1m	M4	CM1L06.41.C	•	•	•	•	•
	12.0	0.6	4	16	24	1m	M4	CM1L06.41.C	•	•	•	•	•
	12.0	0.6	4	16	24	1m	M4	CM1L06.41.C	•	•	•	•	•
	12.0	0.6	4	16	24	1m	M4	CM1L06.41.C	•	•	•	•	•
12000	2.0	0.6	4	16	14	1Am	M4	CM1L06.41.C	•	•	•	•	•
	9.0	0.6	4	16	14	1Am	M4	CM1L06.41.C	•	•	•	•	•
	12.0	0.6	4	16	14	1Am	M4	CM1L06.41.C	•	•	•	•	•

Capacity	Height of Lift	Hoisting Speed		Cross - Travel Speed			FEM	ISO	Type	Trolley Type			
		Slow m/min	Nominal m/min	Slow m/min	Nominal m/min	Ultraspeed m/min				(S)	(M)	(D)	True Vertical Lifting
11500	6.0	1.16			16	24	1Am	M4	CM4L11.11.C	•	•	•	•
	9.0								CM4L11.11.C	•	•	•	•
	12.0								CM4L11.11.C	•	•	•	•
15000	4.0	0.45	1.7		16	14	1m	Mb	CM4L06.61A	•	•	•	•
	6.0								CM4L06.61A	•	•	•	•
16000	6.0	0.6	3.1		16	24	1m	M5	CM4L06.61A	•	•	•	•
	9.0								CM4L06.61A	•	•	•	•
	11.0								CM4L06.61A	•	•	•	•
10000	6.0	0.6	3.5		16	24	2m	M5	CM4L06.61A	•	•	•	•
	9.0								CM4L06.61A	•	•	•	•
	11.0								CM4L06.61A	•	•	•	•
15000	6.0	0.6	3.0		16	14	1Am	M4	CM4L06.61A	•	•	•	•
	9.0								CM4L06.61A	•	•	•	•
	12.0								CM4L06.61A	•	•	•	•
32000	6.0	0.4	1.4		16	14	2m	Mo	CM4L06.61A	•	•	•	•
	9.0								CM4L06.61A	•	•	•	•
	12.0								CM4L06.61A	•	•	•	•
37500	4.0	0.4	1.4		16	14	1Am	M4	CM4L06.61A	•	•	•	•
	6.0								CM4L06.61A	•	•	•	•
	6.0								CM4L06.61A	•	•	•	•

Double Girder EOT Crane

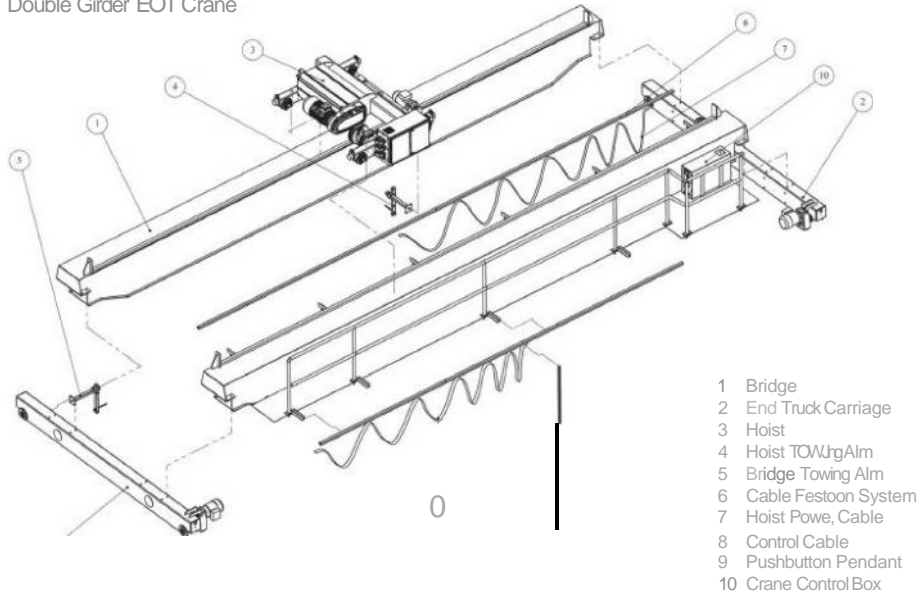

Single Girder EOT Crane

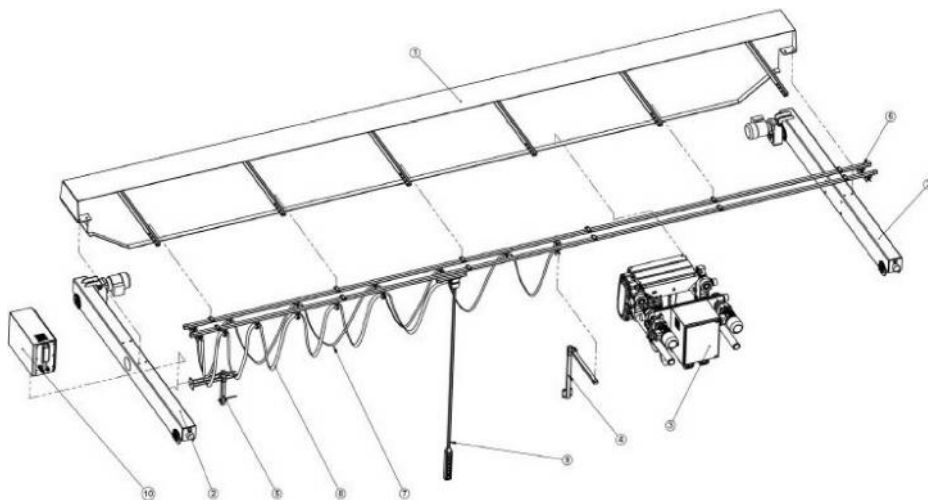

CM SERIES



STANDARD FEATURES

- Double speed by p,19 changing h1g1-quality hoisting moto1. (Standard 6:1 ratio).
- Frequency, nventer controlled cross-travel c,lrve.
- Thermal protection against overheating in hoisting motor.
- Electrical systems have robust design with the 'plugs and sockets' pnnnc1pte.
- Very quiet and smooth operation
- Electro-mechanical overload device
- Electromagnetic OC brake with rubber seal.
- Manual brake release to assist lowering load in case of unexpected power failures.
- 2 layer rotary limit switch in upper and lower positions.
- Direct driven cross-travel mechanisms.
- Articulate crab to ensure positive contact of all wheels with rails
- GGG?0 Graphite Cast Iron Rope Guide with higher flexibility and durability.
- Ergonomic and durable Pushoutton with emergency-stop.
- Operating feed 380-415V @50 Hz I Control voltage 48V
- Long components are covered with high quality Acrylic + Epoxy paint.
- IP55

OPTIONAL FEATURES

- Hoistsense:
 - Real-time monitoring (SWP, remaining duration of service)
 - Increased efficiency with ultraspeed function (except hoisting speed)
 - Weighing display
 - Service optimization
 - Informative Display
- Radio Remote Control
- Regenerative system: 25-40% power saving
- Transformer + Main Contactor for standalone operability
- Suitability to non-standard feeding voltages
- Special modifications for hoisting zone, cold zone, humid zone (from -40 °C to +55 °C)
- Encoder for Hoisting & Cross-travel
- Anti-Sway Application
- Anti-Collision Systems
- External Hoisting and Cross-Travel Cooling Fans
- Surface Hardened Wheels
- Marine Paint





HOISf

Electronic Hoist Monitor & Control Unit



Increase your profitability

HoistSense is an advanced electronic system that constantly keeps track of usage, load and critical incidents; while using these information to the advantage of the user to further increase the efficiency and decrease the downtime of the hoist.

Features

- Real-Time Monitoring
 - Permanent SWP (Safe Working Period) calculation.
 - Up-to-date information about the remaining duration of service
 - Comply with the Regulations.
- Increased Efficiency
 - With UltraSpeed function enabled, HoistSense increases speed to 150% nominal speed on all motions when the load is below 15% of the SWL (Safe Working Load).
- Safe Working
 - Continuous overload protection with precisely calculated strain gauge load measuring system.
- Weighing Display
 - Real-time display of the loads via strain gauge sensor
- Service Optimization
 - Available Alarms for preventive maintenance periods
 - Tracking of Past Maintenances

• Informative Display

- With its display mounted on hoist, the HoistSense informs the operator and maintenance crew for critical information (Total runtime, Number of Overloads, Next Service Hour - Dynamic, Remaining SWP%, Number of Starts, Average Load)
- Comply with the regulations.

• Easy to Use

- HoistSense does not add more buttons or require constantly checking the pushbutton pendant. as the system will start displaying the load on the large display attached to the hoist - easily visible- immediately after the operator starts commanding the crane. And the stored information will be shown on the large display after the hoists stays idle for a short period of time.

Stand-alone Application

- Can be integrated to any of your hoists.

Stored Parameters

- Remaining Safe Working Period (SWP) of the hoist
- Current load on the hook
- Total number of overload incident
- Total running time of the hoisting motor
- Mean load
- Load Spectrum (Light, Medium, Heavy, Very Heavy)
- Total number of starts
- Time to next maintenance (depending on the usage - Dynamic)
- Duty

Functions

- Weighing and Informative Display
- Overload Limiter
- Faster speeds depending on the load
- Dynamic Service Timer



End Truck Carriages



Standard Features

- GGG70 grey cast iron/ forged
- Easily replaceable wheels
- Zinc enhanced epoxy primer coating
- Up to 4m wheel base with 4 wheels per crane or bogie type with up to 8 wheels per crane
- Two flanged wheels
- Maintenance free bearings
- Anti-derail
- Available for top connection, side connection, and top & side connection

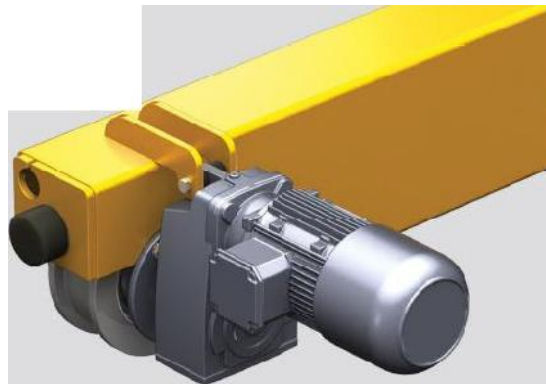

Optional Features

- Manual parking lever
- HRC45 surface hardening
- Rail sweepers and lateral guide rollers

Wheel Diameter	Suitable Standard Rail Width	Standard Wheel Groove!	Custom Wheel Groove!	Dynamic wheel Load	Suitable Drive
GTS125	40	50	SQ,110	2670	CD12
GTS160	50	60	50-110	4520	CD12, C 13
GTS200	50	60	50-110	5660	CD12, C D22, CK13, CKG13, CK11
GTS250	SO	60	SQ,110	7640	CD22, CD32, CK13, CKG13, CK21
GTS315	60	70	50-110	11920	CD32, CD42, CD43, CD52, CD62, CD63, CK33, CK43, CK53
GT-400	70	80	SQ,110	18200	CD32, CD42, CD43, CD52, CD62, CD63, CK33, CK43, CK53
GTS500	70	80	50-110	23430	CD42, CD43, CD52, CD62, CD63, CK43, CK53, CK63, CK73

Wheel load in accordance with FEM 2m/ISO M&M 4 (j,avm)1 nQ(1)nal spez.11_ Subject to finalise without prior notice.

Crane WheelBlocks



Standard Features

- * GGG70 grey cast iron / forged
- * Easily replaceable wheels
- * Zinc enhanced epoxy primer coating
- * Various connection types
- * Two flanged wheels
- * Anti-derail
- * Maintenance free bearings
- * Very modular and flexible for modernizations or new systems

Wheel diameter	Suitable Standard Rail Width	Standard Wheel Groove	Dynamic Wheel Load
GTS160	50	60	4520
GTS200	50	60	5660
GTS250	50	60	7640
GTS315	60	70	11920
GTS400	70	80	18200

Wheel load in accordance with FEM 2m/ISO M&M 4 (j,avm)1 nQ(1)nal spez.11_ and 40m/min nominal speed. Subject to change without prior notice!!!

Optional Features

- .. HRC45 surface hardening

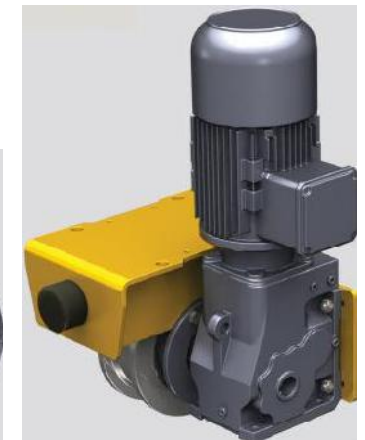
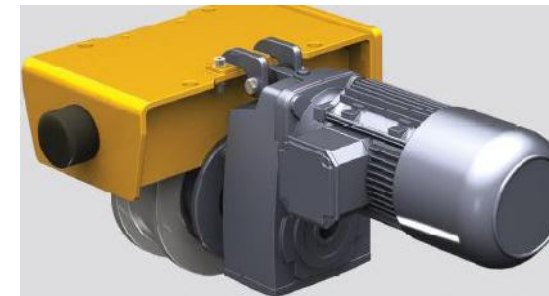

Wheel Rollin Diameter	Code	Description	Groove width	Suitable Drive Types			
				CD12 CK13	CD22 CK23	CD32 CK33	CD42
160	G.160	GTS160 Wheel Block Non Driven	60				
	G.160TI	GTS160 Wheel Block Driven e30	60	X			
200	G.200	GTS200 Wheel Block Non Driven	60				
	G.200TI	GTS200 Wheel Block Driven e30	60	X			
250	G.250	GTS250 Wheel Block Non Driven	60		Only CD22		
	G.250TI	GTS250 Wheel Block Driven e35	60				
315	G.31S	GTS315 Wheel Block Non Driven	75				
	G.315TI	GTS315 Wheel Block Driven e35	75				
400	G.400	GTS400 Wheel Block Non Driven	80				
	G.400TI	GTS400 Wheel Block Driven e40	80				
	G.400TI	GTS400 Wheel Block Driven eSO	80			Only CD22	X

* "X" means both options are available. S1,1b,eece(l),h s,iv,rthi...nprfem,ee,c..



*SUPER TARGET
MIDDLE EAST
FZ. LLC*

Contact Us

TEL : +971 2 5593044

CEL : +971 52 7282308

EMAIL : info@supertargetmiddleeast.com

EMAIL : sales@supertargetmiddleeast.com

WEB : www.supertargetmiddleeast.com

Ras Al Khaimah Economic Zone

United Arab Emirates