

FLEXY KITS

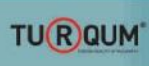

Modular Crane Kit Packages

www.cmak.com



FLEXY-KIT PROGRAM

- (,,_ Top-notch engineering
- ’ Significantly cost-saving
- Optimized for shipping
- , Available in 3.2t, 5t and 10t both CM or CMK hoist.
- L ISPM 15 Wooden/ Corrugate box packaging

STANDARD COMPONENTS

- Hoist
- End-truck carriages
- Long-travel drives
- Bridge control panel
- Festoon system and c-profile
- Crane power towing arm
- Hoist power towing arm

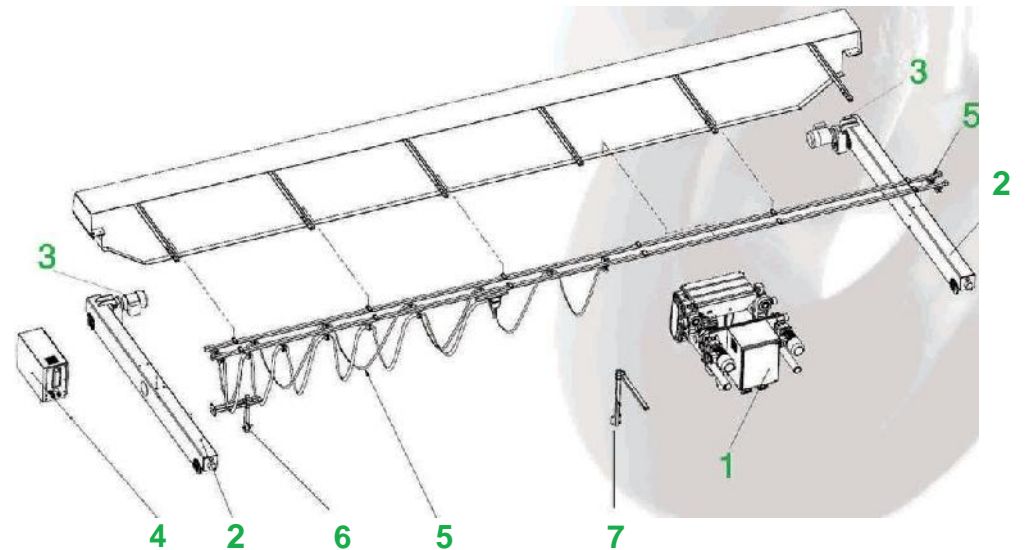



Crane-kit ordering has never been that easy!

CMAK Crane System is an expert engineering and manufacturing company, which excels at high quality crane components. In addition to our crane systems that are produced with the world's leading technology, we provide traditions, ethical merits and our engineering success to our customers.

Now we also provide a new innovative crane-kit program to the industrial crane market. These kits contain everything required for a crane except the beam(s). Flexy kits have also proven to be reliable and cost-effective when the prompt delivery is critical. It takes crane-kit ordering process to another level.

1. SINGLE GIRDER LOW-HEADROOM ELECTRIC WIRE ROPE HOIST

CMK Series



*CMK series with hoistsense option

CM Series



- Adjustable with 2 chromium coated rods. (150-200mm bottom flange width)
- Suitable for any type of beam. Any world standard flat or tapered beams. hybrid beams, box beams. (has to be stated at ordering)
- No drive shaft to drive two sides, in other words only direct driven casted wheels.
- No open gears; Extreme endurance
- Modular casted chassis.
- Ultra compact hook side approach
- Standard rollers for counter weight, optionally can also have counter weight.

2. END-TRUCK CARRIAGES

A. Standard type B. Wheel block type



- Suits up to 21m (68.89 ft) span
- GTS type direct driven system
- GGG70 Graphite Cast Iron wheels
- Torque-arm connection
- 21000, 22000, 23000 series bearings even durable against unwanted side loads
- Standard bolted girder connection plates

3. LONG-TRAVEL DRIVES



- Fully assembled motor/gearbox/brake for easy installation
- Electromagnetic DC brake
- Helical geared F insulation class motors
- IP55 protection

4. BRIDGE CONTROL PANEL



- Control panel with plug/socket connection
- Standard Variable Frequency Control

5. FESTOON SYSTEM AND C-PROFILE



- Low cost and efficient operation
- Can be attached to the girder with bolts
- Mobile control
- Durable cable trolley

6. ACCESSORIES

We offer 3 types of accessories as below. You can select one of the suitable accessories for your flexy crane-kits.

ECO

1- Pushbutton Pendant with Cable

- 6+ 1 Pushbutton with cable
- IP65 protection
- Plug/Socket connection



OPTIMAL

1 Pushbutton Pendant with Cable

- 6+ 1 Pushbutton with cable
- IP65 protection
- Plug/Socket connection

2 Limit Switch

- For Cross-travel and Long-travel motions
- 2 level (stop/stop)
- Metal housing and cover
- IP65 protection

3 Wheel Heat Treatment

- Long-travel wheels with 45 HRC surface hardness



PREMIUM

1 Pushbutton Pendant with Cable

- 6+ 1 Pushbutton with cable
- IP65 protection
- Plug/Socket connection

2 Limit Switch

- For Cross-travel and Long-travel motions
- 2 level (stop/stop)
- Metal housing and cover
- IP65 protection

3 HoistSense

- Weighing and Informative Display
- Faster speed depending on the load
- Overload Limiter
- Dynamic Service Timer

4 Radio Remote Control

- 8x 2 step buttons
- 16 selectable channels
- Exchangeable batteries
- IP65 protection

5 Wheel Heat Treatment

- Long-travel wheels with 45 HRC surface hardness

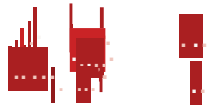

* Stocks get replenished throughout t11eyears.

3.2 TON-CM1

3.2 Metric ton (3.5 Short ton) capacity
6m (19.7 ft) height of lift
380-460V 50/60hz, 48 VIC
Suitable up to 21m (68.9 ft) crane span
21m Plug & Play festoon package
Hoisting:

Motor power:
 - 3 kW (4 hp) @380V
 - 3.6 kW (4.8 hp) @460V
 - 3000 rpm @50hz
 - 3600 rpm @60hz
 - Infinitely variablespeed variaton- Standard 6:1 ratio

Speed:
 - 1.0...3.9m/min (3.3...12.8 ft/min) @50hz- VFD
 - 1.2...4.62m/min (3.9...15.2ft/min) @60hz- VFD

Cross-travelling:

Motor power:
 - 2x 0.25kW (2x 0.33hp) @380V
 - 2x 0.3kW (2x 0.4hp) @460V
 - 1500 rpm @50hz
 - 1800 rpm @60hz
 - Infinitely variablespeed variaton- Standard 4:1 ratio

Speed:
 - 4...16m/min (13.1...52.4ft/min) @50hz- VFD
 - 4.8...19.2m/min (15.7...62.9 ft/min) @60hz- VFD

Long-travelling:

Motor power:
 - 2x 0.55kW (2X 0.73hp) @380V
 - 2x 0.66kW (2X 0.88hp) @460V
 - 1500rpm @50hz
 • 1800rpm @60hz
 - Infinitely variablespeed variaton- Standard 4:1 ratio

Speed:
 - 10...40 m/min (32.8...131.2 ft/min) @50hz- VFD
 - 12...48 m/min (39.4...157.4 ft/min) @60hz-VFD

Endtruck carriages:

Standard type
 - 0160mm wheels
 - 3000mm (118") wheelbase
 - Suitable for 50mm (2") rail width
 - Standard 60mm (2.37") wheel tread width.

Wheelblock type

- 0160mm wheels
 - Suitable for 50mm (2") rail width
 - Standard 60mm (2.37") wheel tread width.

5 TON-CMK25

5 Metric ton (5.5 Short ton) capacity
8.2m (26.9ft) height of lift
380-460V 50/60hz, 48 VIC
Suitable (up to) 21m (68.9 ft) crane span
21m Plug & Play festoon package
Hoisting:

Motor power:
 - 5.5kW (7.4 hp) @380V
 - 6.66kW (8.9 hp) @460V
 - 3000 rpm @50hz
 - 3600 rpm @60hz
 - Infinitely variablespeed variaton- Standard 6:1 ratio

Speed:
 - 0.8...5 m/min (2.6...16.4 ft/min) @50hz-VFD
 - 1...6 m/min (3.3...19.7 ft/min) @60hz-VFD

Cross-travelling:

Motor power:
 - 2x 0.37kW (2x 0.5hp) @380V
 - 2x 0.6kW (0.8hp) @460V
 - 1500rpm @50hz
 - 1800rpm @60hz
 - Infinitely variablespeed variaton - Standard 4:1 ratio

Speed:
 - 4...16m/min @50hz (13.1...52.4ft/min @50hz)- VFD
 - 4.8...19.2m/min @60hz (15.7...63.0ft/min @60hz)-VFD

Long-travelling:

Motor power:
 - 2x 0.75kW (2x 1 hp) @380V
 - 2x 0.9kW (2X 1.2hp) @460V
 - 1500rpm @50hz
 - 1800rpm @60hz
 • Infinitely variablespeed variaton - Standard 4:1 ratio

Speed:
 - 10...40m/min @50hz (32.8...131.2ft/min @50hz)- VFD
 - 12...48m/min @60hz (39.4...157.5ft/min @60hz)- VFD

Endtruck carriages:

Standard type
 - 0160mm wheels
 - 3000mm (118") wheelbase
 - Suitable for 50mm (2") rail width
 - Standard 60mm (2.37") wheel tread width.

Wheelblock type

- 0160mm wheels
 - Suitable for 50mm (2") rail width
 - Standard 60mm (2.37") wheel tread width.

5 TON-CM2

5 Metric ton (5.5 Short ton) capacity
6m (19.7ft) height of lift
380-460V 50/60hz, 48 VIC
Suitable (up to) 21m (68.9 ft) crane span
21m Plug & Play festoon package
Hoisting:

Motor power:
 - 4.9/0.8 kW (6.6/1.1 hp) @380V
 - 5.9/1 kW (7.9/1.3hp) @460V
 - 3000 rpm @50hz
 - 3600 rpm @60hz
 - Constant speed variaton- Standard 6:1 ratio

Speed:
 - .7 m/min (13.1/2.3 ft/min) @50hz
 - 4.8/0.8m/min (15.7/2.6 ft/min) @60112

Cross-travelling:

Motor power:
 - 2x 0.37kW (2x 0.5 hp) @380V
 - 2x 0.6kW (0.8hp) @460V
 - 1500 rpm @50hz
 - 1800 rpm @60hz
 - Infinitely variable speed variaton - Standard 4:1 ratio

Speed:
 - 4...16m/min @50hz (13.1...52.4ft/min @50hz)- VFD
 4- 8...19.2m/min @60hz (15.7...63.0ft/min @60hz)-VFD

Long-travelling:

Motor power:
 - 2x 0.75 kW (2X 1 hp) @380V
 - 2x 0.9 kW (2x 1.2hp) @460V
 - 1500 rpm @50112
 - 1800 rpm @60112
 - Infinitely variable speed variaton - Standard 4:1 ratio

Speed:
 - 10...40m/min @50hz (32.8...131.2ft/min @50hz)-VFD
 - 12...48 m/min @60hz (39.4...157.5ft/min @60hz)-VFD

Endtruck carriages:

Standard type
 - 0160mm wheels
 - 3000mm (118") wheelbase
 - Suitable for 50mm (2") rail width
 - Standard 60mm (2.37") wheel tread width.

Wheelblock type

- 0160mm wheels
 - Suitable for 50mm (2") rail width
 - Standard 60mm (2.37") wheel tread width.

10 TON- CMK35

10 Metric ton (11 Short ton) capacity
7.5m (25.6ft) height of lift
380-460V 50/60hz, 48 VIC
Suitable (up to) 21m (68.9 ft) crane span
21m Plug & Play festoon package
Hoisting:

Motor power:
 - 11kW (14.8hp) @380V
 - 13.3kW (17.8hp) @460V
 - 3000 rpm @50hz
 - 3600 rpm @60hz
 - Infinitely variablespeed variaton- Standard 6:1 ratio

Speed:
 - 0.8...5.1 m/min (2.6...16.7 ft/min) @50hz- VFD
 - 1 ...6.1 m/min (3.3...20 ft/min) @60hz- VFD

Cross-travelling:

Motor power:
 - 2x 0.37kW (2x 0.5 hp) @380V
 - 2x 0.6kW (0.8hp) @460V
 - 1500rpm @50hz
 - 1800 rpm @60hz
 - Infinitely variablespeed variaton- Standard 4:1 ratio

Speed:
 - 4...16m/min @50hz (13.1...52.4ft/min @50hz)- VFO
 4- 8...19.2m/min @60hz (15.7...63.0ft/min @60hz)-VFD

Long-travelling:

Motor power:
 - 2x 1.5kW (2X 2 hp) @380V
 - 2x 1.8kW (2x 2.4hp) @460V
 - 1500 rpm @50112
 - 1800 rpm @60hz
 - Infinitely variablespeed variaton - Standard 4:1 ratio

Speed:
 - 10...40m/min @50hz (32.8...131.2ft/min @50hz)- VFD
 - 12...48m/min @60hz (39.4...157.5ft/min @60hz)-VFD

Endtruck carriages:

Standard type
 - 0250mm wheels
 - 3000mm (118") wheelbase
 - Suitable for 50mm (2") rail width
 - Standard 60mm (2.37") wheel tread width.

Wheelblock type

- 0250mm wheels
 - Suitable for 50mm (2") rail width
 - Standard 60mm (2.37") wheel tread width.

10 TON- CM3

10 Metric ton (11 Shortton) capacity
6m (19.7 ft) height of lift
380-460V 50/60hz, 48 V/C
Suitable (upto) 21m (68.9 ft) crane span
21m Plug & Play festoon package
Hoisting:

Motor power:
 • 9.5/1.6kW (12.7/2.1hp) @380V
 - 11.5/1.9kW (15.4/2.5hp) @460V
 - 3000 rpm @50hz
 - 3600 rpm @60hz
 - Constant speed variaton • Standard 6:1 ratio

Speed:
 - 4/0.6m/min (13.1/2ft/min) @50hz
 - 4.8/0.7m/min (15.7/2.3 ft/min) @60hz

Cross-travelling:

Motor power:
 - 2x 0.37kW (2x 0.5 hp) @380V
 - 2x 0.6kW (0.8 hp) @460V
 - 1500rpm @50hz
 - 1800 rpm @60hz
 - Infinitely variablespeed variaton - Standard 4:1 ratio

Speed:
 - 4...16m/min @50hz (13.1...52.4 ft/min @50hz)- VFD
 - 4.8...19.2 m/min @60hz (15.7...63.0 ft/min @60hz)-VFD

Long-travelling:

Motor power:
 - 2x 1.5kW (2x 2hp) @380V
 - 2x 1.8kW (2x 2.4 hp) @460V
 - 1500rpm @50hz
 - 1800 rpm @60hz
 - Infinitely variablespeed variaton - Standard 4:1 ratio

Speed:
 - 10...40 m/min @50hz (32.8...131.2ft/min @50hz)- VFD
 - 12...48 m/min @60hz (39.4...157.5 ft/min @60hz)-VFD

Endtruck carriages:

Standard type
 - 0250mm wheels
 - 3000mm (118") wheelbase
 • Suitable for 50mm (2") rail width
 - Standard 60mm (2.37") wheel tread width.

Wheelblock type

- 0250mm wheels
 - Suitable for 50mm (2") rail width
 - Standard 60mm (2.37") wheel tread width.

** CMAK Crane Systems may alter or amend the technical features identified herein at any time with or without notice

CMAK.TOOLS

Sit back and leave the rest to CMAK. Tools and CMAK 3D

CMAK Crane Systems present the CMAK.Tools, a crane-manufacturers' right hand, which can support you as:

A salesman:

- Preparing accurate configurations of the crane(s) your customer needs, with your accurate pricing
- Preparing neat offer documents
- Estimating the sizes and options
- Configurable to anything you are selling about cranes
- Prepare unscaled general assembly drawings in seconds

A mechanical engineer:

- Do calculation and/or testing of crane structures (box, standard profiles and so on) in minutes
- Do calculation and/or testing of crane runways (box, standard profiles, welded profiles, with different calculation methods) in minutes.
- Find out the best section or selection for your application via "Optimizer" embedded to the calculators.

Optimize your customer needs regarding the duty they require, even find out the duty they require according to FEM standards



CMAK.3D

Cmak.3D Drawing generator which can be accessed via Cmak. Tools shows exact scaled drawing of the cranes that your partners require anytime of the day. In under 20 minutes you can receive:

- 3D Model Drawing
- General assembly drawing in dxf format,
- Manufacturing drawings including welding and cutting schemes,
- Even enc cutter drawings of the crane structure

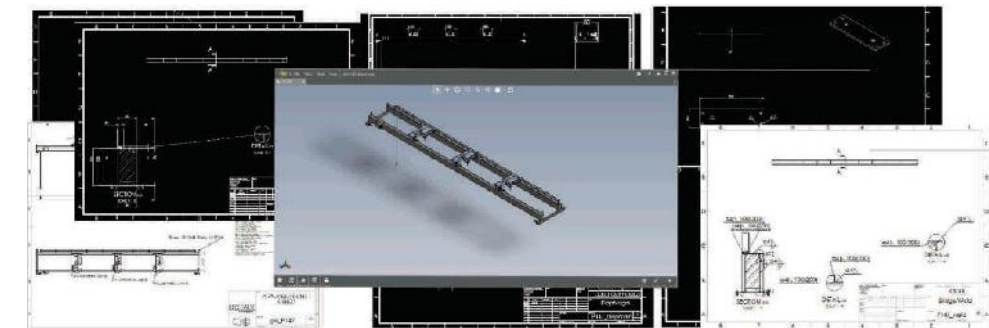
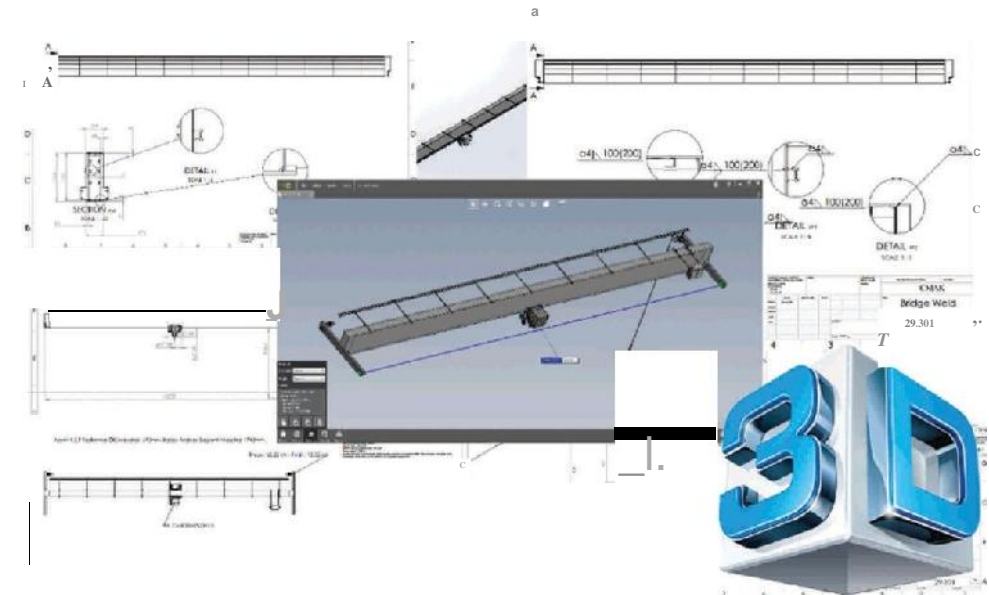



*SUPER TARGET
MIDDLE EAST
FZ. LLC*

Contact Us

TEL : +971 2 5593044

CEL : +971 52 7282308

EMAIL : info@supertargetmiddleeast.com

EMAIL : sales@supertargetmiddleeast.com

WEB : www.supertargetmiddleeast.com

Ras Al Khaimah Economic Zone

United Arab Emirates