



# NXS

5th Generation High-Technology Electric Wire Rope Hoist



NXS25 - NXS35 - NXS45 - NXS55 - NXS70 - NXS90 - NXS110  
Series



## OUR STORY



### Founded in 1977

Vast knowledge in industrial cranes and material handling applications



### Family Business

Laws on continuity and integrity



### Corporate culture

Emphasises strictly on business ethics, and longterm business success



### Our core strengths

Come from engineering with scientific R&D



### Smart Design

Focus solely on high quality production with smart desing

CMAK Crane Systems is an expert engineering and manufacturing company, focusing on high-quality electric crane components.

We reach customers worldwide, through the partners thanks to our affordable products that are produced in one of the most modern production facilities. In addition to our crane systems that are produced with the world's leading technologies, we offer traditions, business ethics and engineering success to the customers.

CMAK productions meet the needs of the market in standard capacity cranes with FEM class, in addition to that, we manufacture high capacity cranes with custom designs.

With continuous research and development, we've formed an ergonomic design that leads to easy maintenance and minimum service requirement.



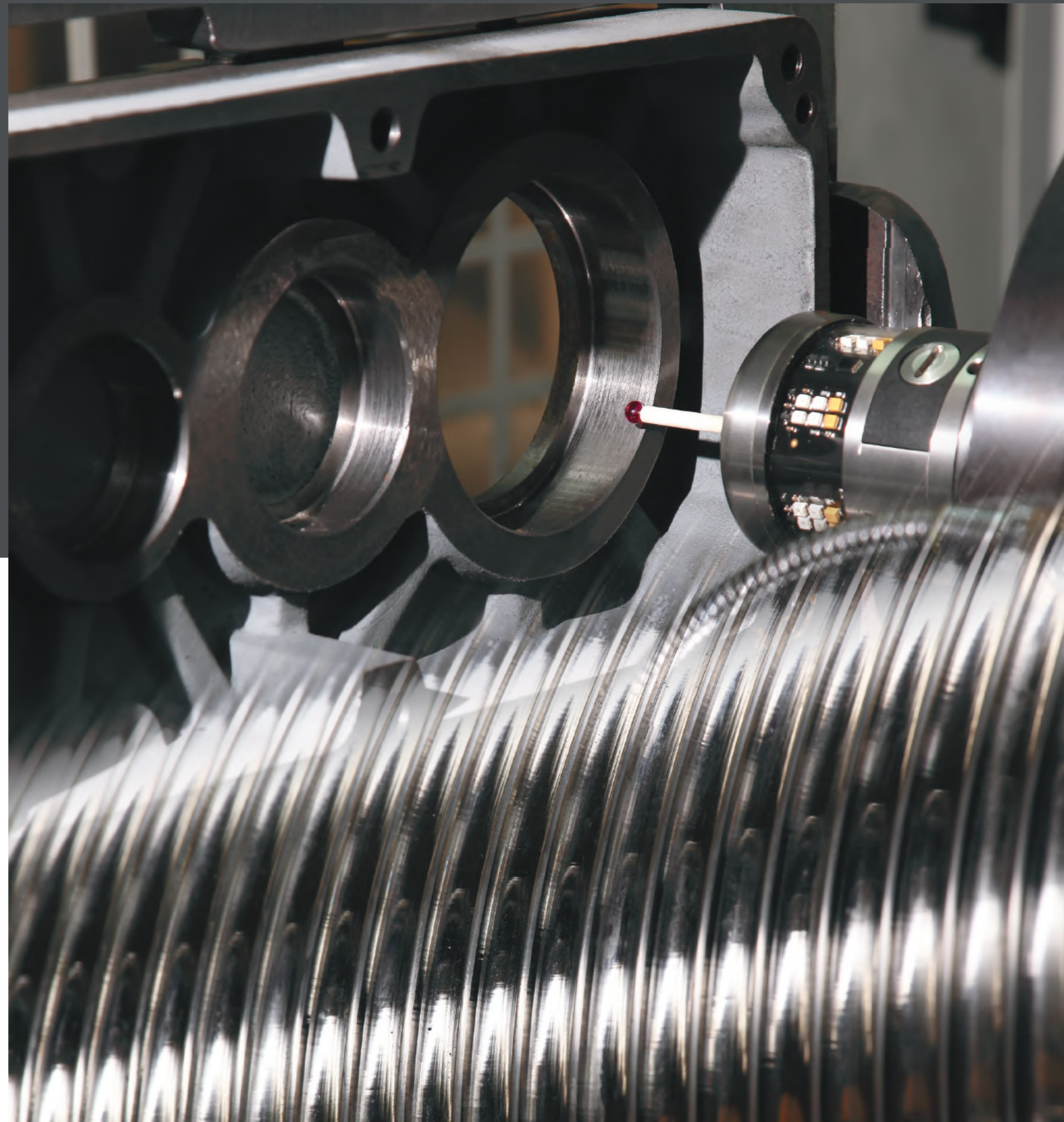
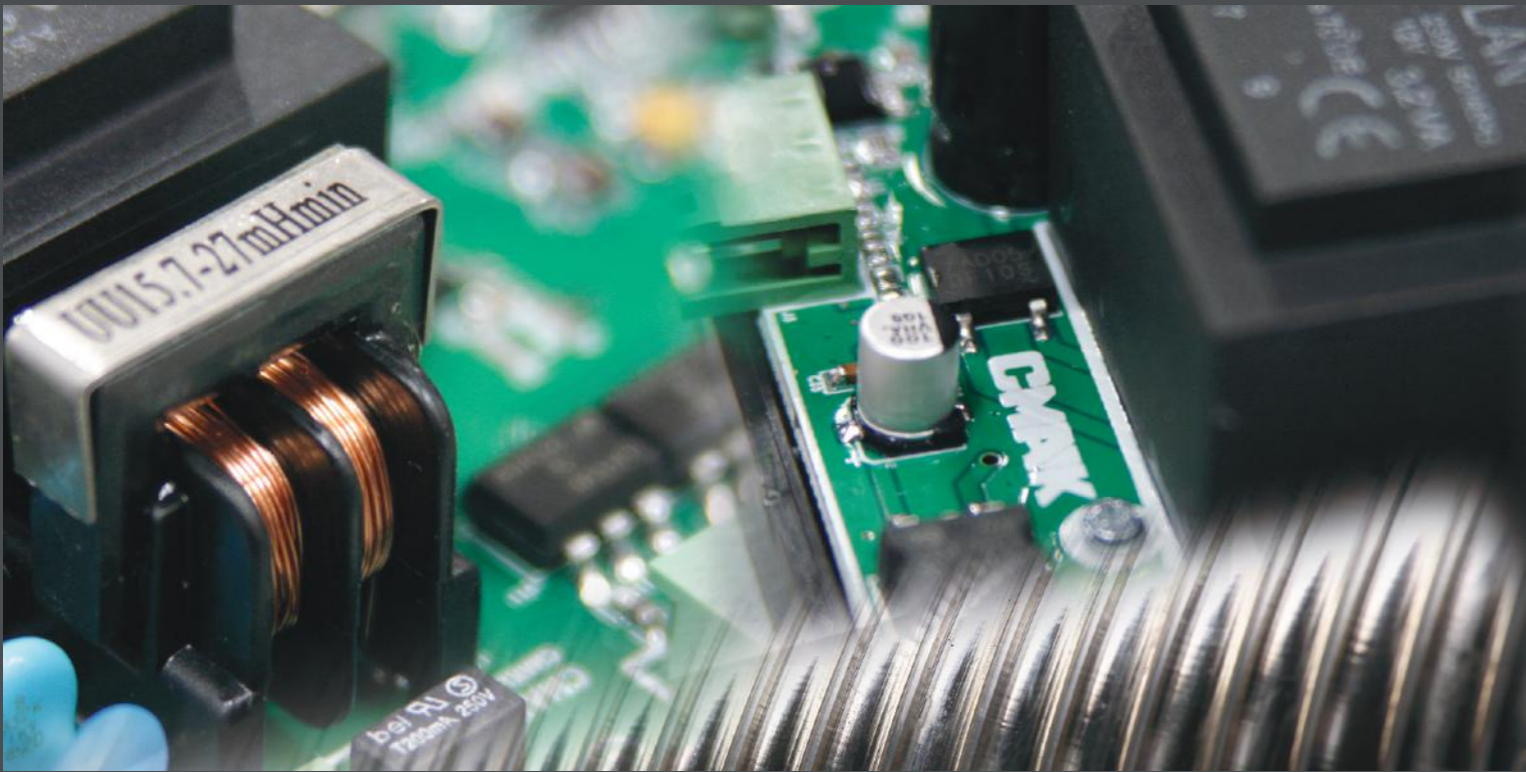

**STM** | SUPER TARGET  
MIDDLE EAST  
FZ. LLC

“ Gathered from the feedback of the relatively old design hoists, CMAK developed a hoist that is superior and still cost-effective.

We present the future with NXS series

”



# ADVANTAGES



## High Technology

### ROBUST DESIGN

NXS series electric wire rope hoists come with modular casted chassis & direct-driven forged wheels designed to give extreme endurance with a high level of productivity. The hoists are adjustable with two chromium rods between 150mm-500mm bottom flange width and are also, suitable for any world standard beams such as flat, tapered, hybrid, or box beams.



## Maximum Height of Lift

### LARGE DRUM DIAMETER

Compared to the conventional systems, NXS hoists are equipped with a large diameter rope drum, enabling it to have the maximum number of reeving for easily reaching high lifting heights. With its innovative design, lifting and lowering are done with minimal hook drift, similar to absolute vertical lifting systems.



## High Efficient Lifting Motors

### ADAPTABLE DESIGN

NXS series hoists are equipped with pole-changing or stepless inverter-controlled AC induction squirrel-cage motors. Thus with the changeable speed ratio, the operation experiment is accurate with low speed, faster with high speed.



## Increased Falls Capability

### SMART FALLS SYSTEM

With the compact pulley system, NXS hoists have higher falls without increasing the size of the hoist. In this way, it can provide greater lifting capacities using smaller hoisting groups.



## High-performance Polymer Rope Guide

### ROPE GUIDE

With high-performance polymer rope guide, the wire rope is tightly rolled to the drum, and thanks to its flexibility, it minimizes the breakage due to wrong usage. This special design provides robust chemical resistance and long service life.



## Maximum Wire Rope Service Life

### DURABLE WIRE ROPE

NXS series electric wire rope hoists are equipped with 2160N/mm<sup>2</sup> grade high tensile strength steel wire rope. The bending angle of NXS hoists' wire rope is far smaller than conventional hoists thus increasing the service life of the wire rope by five times.



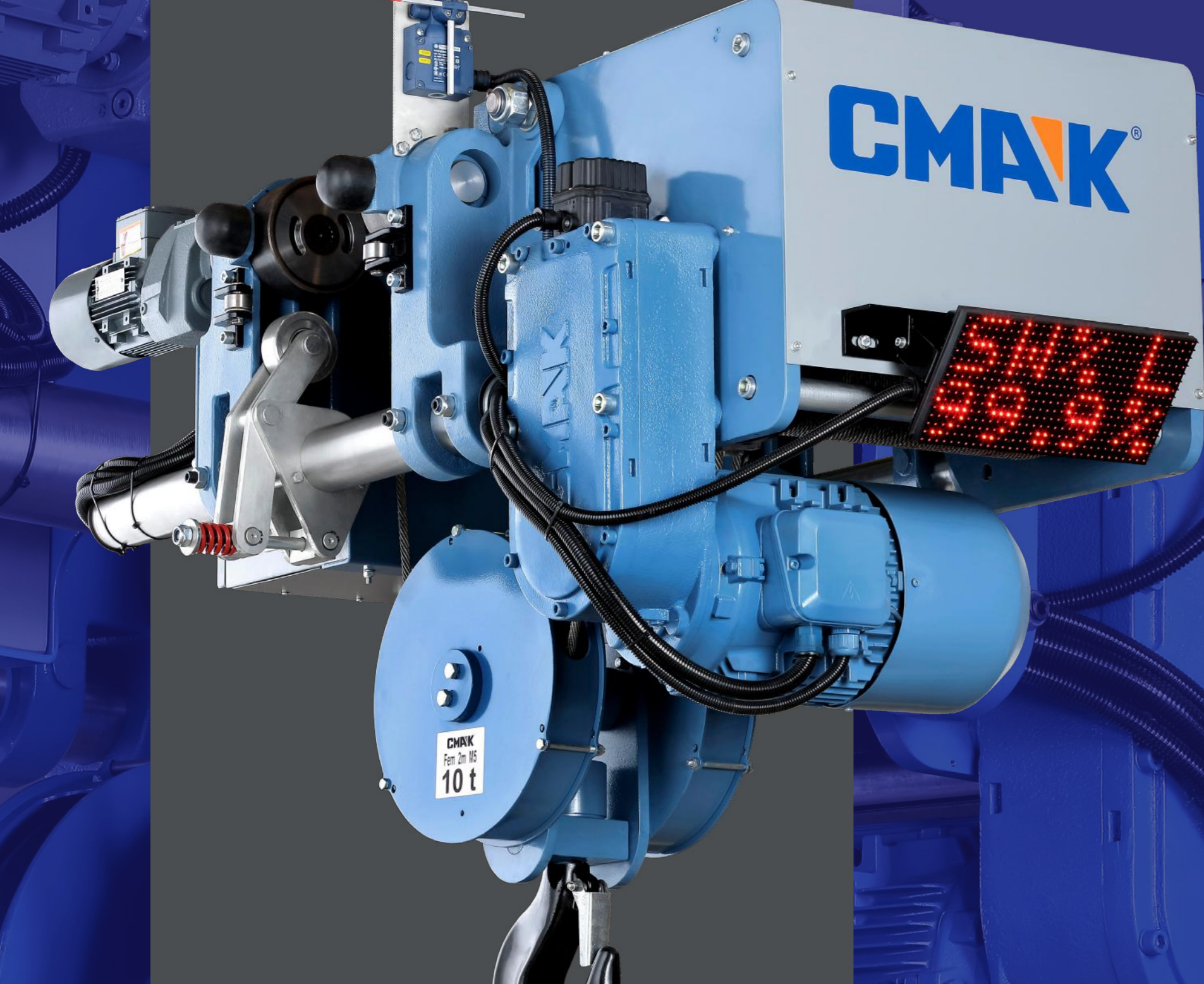

#### Minimum Hook Drift

##### SHORT DRUM LENGTH

Thanks to the NXS series hoists' design, lifting and lowering is done with minimal hook drift, similar to absolute vertical lifting systems.



#### Direct Driven Drivers

##### GTS TYPE TRAVEL MECHANISM

NXS Travel wheels of the hoists are direct driven thus minimises the wear on travel mechanisms.



#### Maximum Power Economy

##### REGENERATIVE ENERGY (OPTIONAL)

While lowering, the system feeds back the motors with surplus energy while decreasing the overall consumption of electricity between 25%-40% of a crane. NXS hoists are kind to earth.



#### Variable Cross Travelling Speeds

##### SMOOTH ACCELERATION & DECELERATION

All cross-travel or longitudinal motions are driven by the inverters. In addition to that, with preset acceleration/ deceleration ramps, there is minimal wear on the cross-travel mechanism thus extending the service life with smooth running.



#### Special Bottom and Top Two-step Limiter

##### ACCURATE & DURABLE LIMITS

NXS series hoists have two-level top and bottom hook travel limiters which are easily adjustable to ensure trouble-free operation. In case of a hook gets close to top or bottom limits, hoisting will get automatically stopped at the extreme limit set. This ensures a far healthy and safe operation.



#### Electro-mechanical Overload Device

##### SAFE LOAD LIMITER

NXS series electric wire rope hoists are equipped with an overload limiter in standard. Electro-mechanical overload device can be easily adjusted with an Allen wrench to ensure safe operation. With preset values, in case of lifting heavier loads than the nominal load, the lifting operation is stopped immediately to avoid damage to the machinery, system, and most importantly your building.





### Long Service Life

#### HOIST PROTECTION SYSTEM

NXS series hoists are equipped with PTC, Thermic, Phase safe-Guard, Emergency System, Top and Bottom Limiters, and overload limiters. These high-technology hoists are also compatible with ISO, FEM, and CE norms, thus they are very reliable and safely operational.



### Minimum Maintenance Requirement

#### LONG SERVICE LIFE

Every part of NXS series hoist can be easily disassembled for effective maintenance and part replacement. In terms of mechanical structure and electrical system, NXS series electric wire rope hoists are designed with the "plug/remove" principle. NXS series hoists are designed to endure severe conditions for years.



### Manual Brake Release (Optional)

#### MANUAL LOAD LOWERING

NXS series electric wire rope hoists' hoisting motor is adaptable with manual brake release, thus in case of unexpected power failures, the loads can be lowered to the ground manually using the manual brake release.



### Safe Operation

#### EMERGENCY SYSTEM

In an emergency, the operator can simply press the emergency stop button, located at the bottom of the pushbutton, to cut the main power of the crane. Also in situation of power surges, NXS hoists will automatically cut the main power to avoid its systems getting damaged.



### Service Optimization

#### INTELLIGENT MAINTENANCE SUPPORT

NXS series hoists can be equipped with HoistSense+ Electronic Monitoring System, which allows the operators and service crew to optimize the service dates thus minimising the downtime and maximising the efficient operation time.



### Operator Health First

#### LOW CONTROL VOLTAGE

NXS Hoist's standard Control Voltage is 48V. In case of an insulation problem on the pushbutton, due to a direct damage, only 48V electricity is on the circuits that are close to the operator's hand.

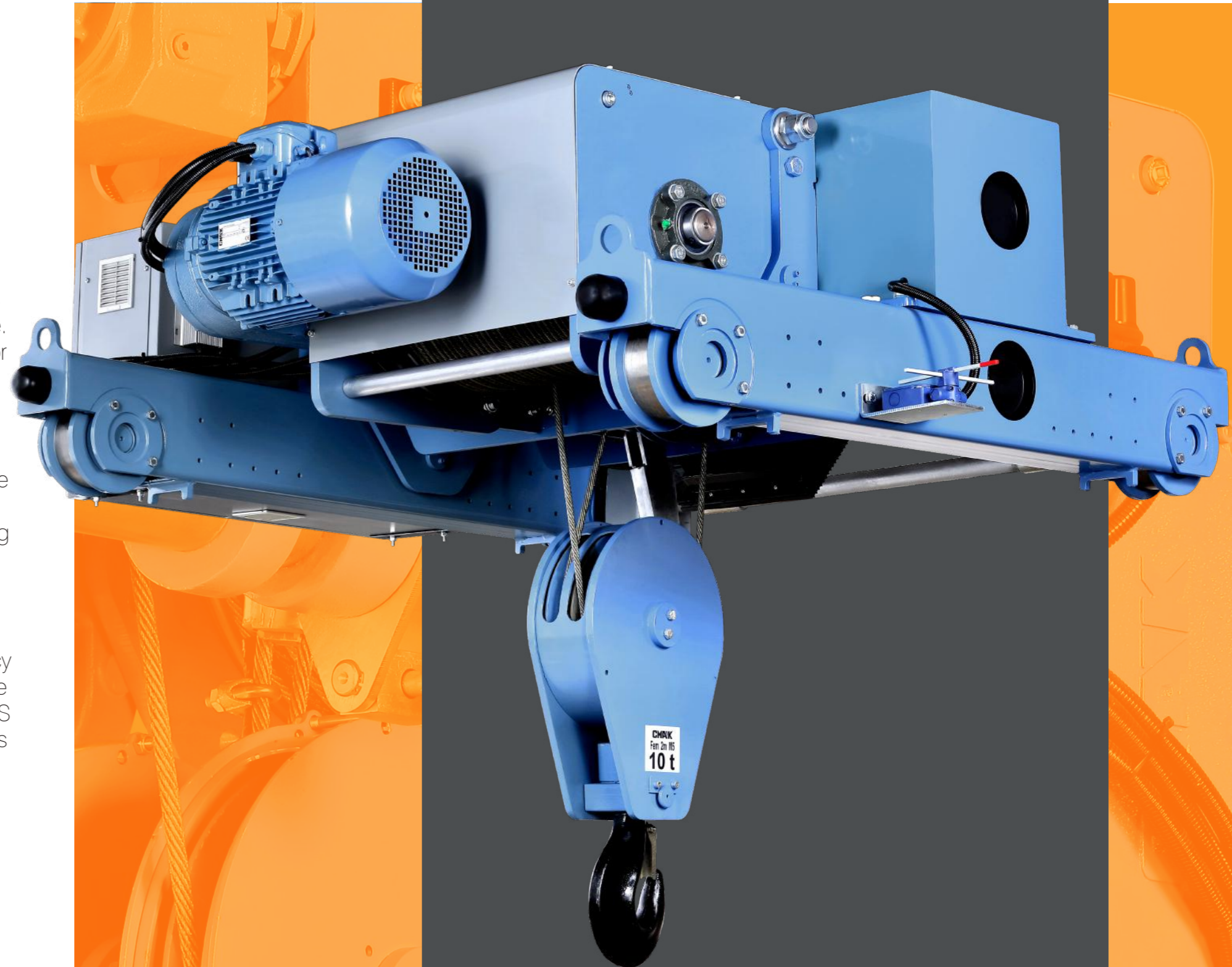

# STANDARD FEATURES

- Frequency inverter controlled or Double speed by pole changing high-quality hoisting motor.
- Frequency inverter controlled cross-travel drives.
- Very quiet and smooth operation.
- Mechanical structure and electrical systems have a modular design with the 'plugs and sockets' principle.
- Hoisting motors with H-insulation classification.
- Lifting and lowering actions with minimal hook drift.
- Electromagnetic DC brake with rubber seal.
- Electro-mechanical overload device to avoid damage to the machinery, system and building.
- 4 layer rotary limit switch with slow-down/stop functions in upper and lower positions.
- Direct driven cross-travel mechanisms.
- IP55 - Protection.
- Articulated crab to ensure positive contact of all wheels with rails.
- High-performance acid resistance polymer wire rope.
- Ergonomic and durable Pushbutton with emergency stop.
- Operating feed: 380-415V @50 Hz / Control voltage: 48V.
- Lifting components are finished with sandblasting then high-quality C3 -Acrylic + Epoxy paint.

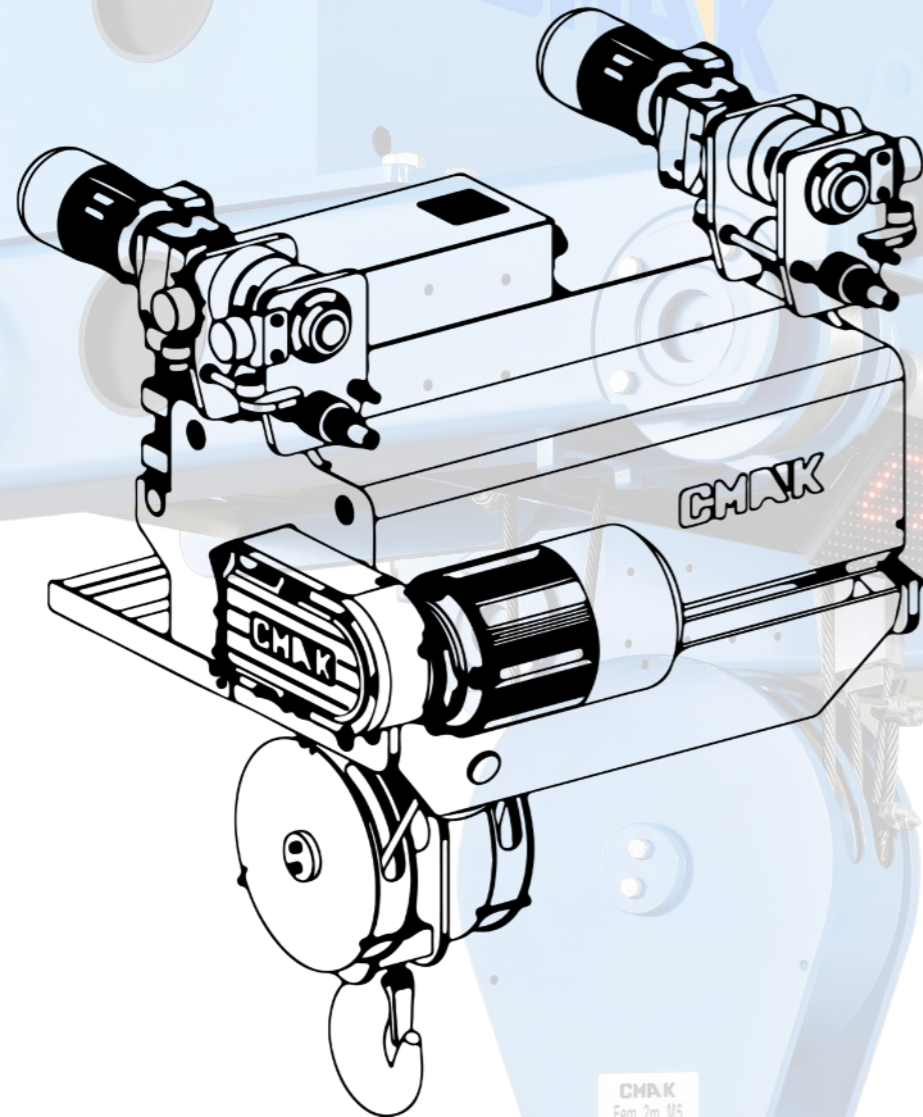

# OPTIONAL FEATURES

- Hoistsense+ :
  - Real-time monitoring SWP, remaining duration of service).
  - Increased efficiency with ultra-speed function
  - Weighing display
  - Service optimization
  - Informative Display.
- Two hoists on one trolley.
- Tandem operation.
- Custom hoist gauge.
- Radio Remote Control.
- Regenerative system 25-40% power saving.
- Transformer + Main Contact for standalone operability.
- Suitability to non-standard feeding voltages.
- Special modifications for hot zone, cold zone, humid zone (from -40 °C to +55 °C.).
- Encoder for Hoisting & Cross-travel.
- Anti-Sway Application.
- Anti-Collision Systems.
- Manual Brake Release for Hoisting Drive.
- External Hoisting and Cross-Travel Cooling Fans.
- Non-standard creep/fast speed ratio.
- Surface Hardened Wheels.
- Cast iron rope guide.
- C5-M Marine Paint.
- Up to IP66 protection.

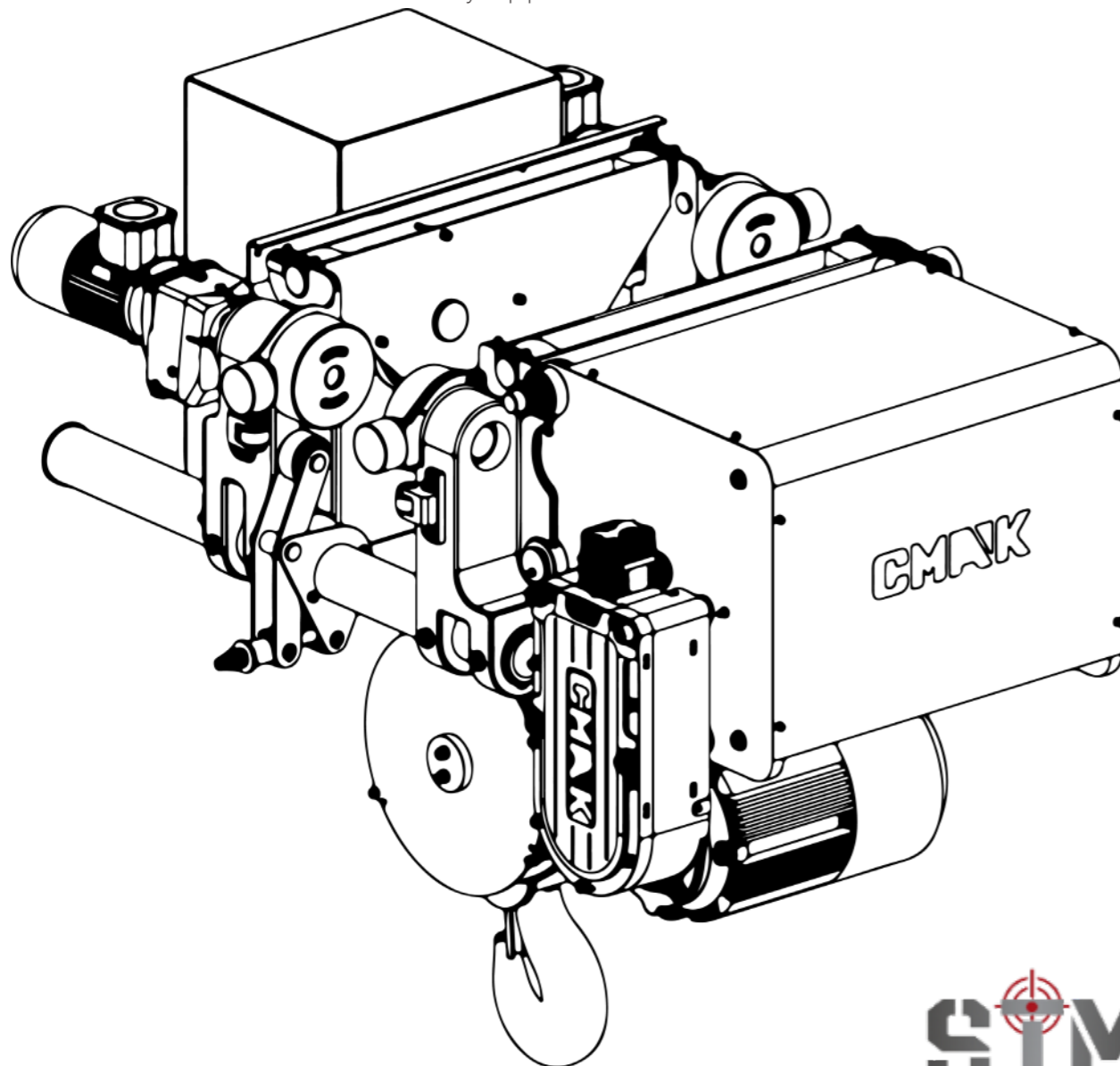

# High Potentials

NXS wire rope adaptable design concept provides efficient and economical solutions for high lifting heights. Compared to old designs, NXS hoist with G-type drum enabling the maximum number of reeving for easily reach lifting heights up to 240m.



# HoistSense+

HS+ is an advanced electronic system that constantly keeps track of usage, load and critical incidents; while using this information to the advantage of the user to further increase the efficiency and decrease the downtime of the hoist. Here is why it's a GREAT option to consider for your crane

- Real-Time Monitoring
- Increased Efficiency
- Safe Working
- Load-Sharing
- Slack Rope Supervision
- Weighing Display
- Service Optimization

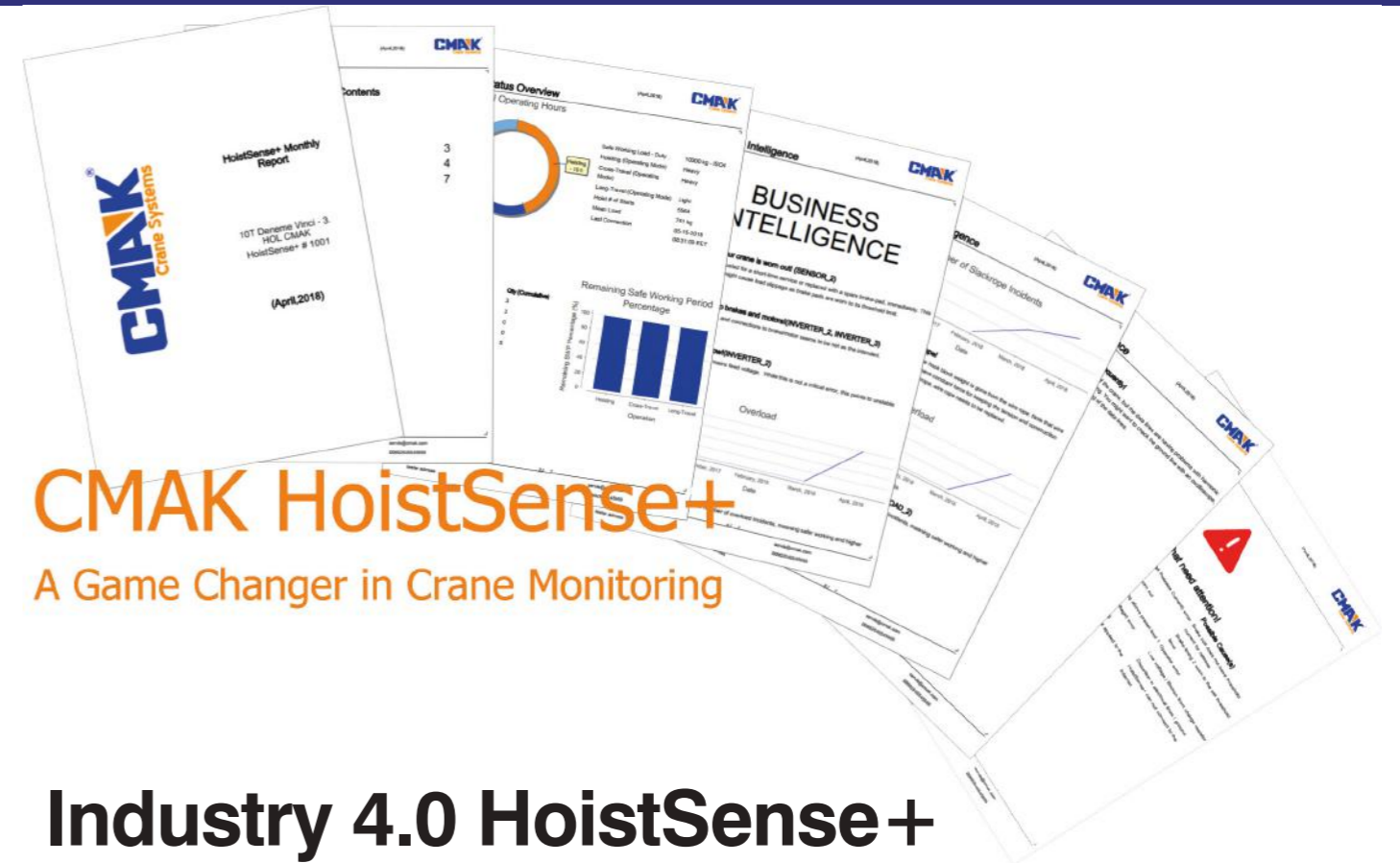

## CMAK HoistSense+ A Game Changer in Crane Monitoring

### Industry 4.0 HoistSense+

HS+ with expandable gateway module for the internet connection ( via mobile data and/ or WiFi and/or ethernet ), original HS+ closed loop system gets to another level at value generation.

Alarm and notifications of sensors can be immediatly formed into an email and sent to your email groups. Statistical wrong usages can be analyzed and users can be warned or trained for using their cranes efficiently and effectively. Periodical reports can be generated for end-users archives ( weekly, monthly, quarterly, annually ).

HS+ communicates with Inverters of the crane, and it lets it grab any error or alarm message immediatly and send it to the end-users, depending on settings.

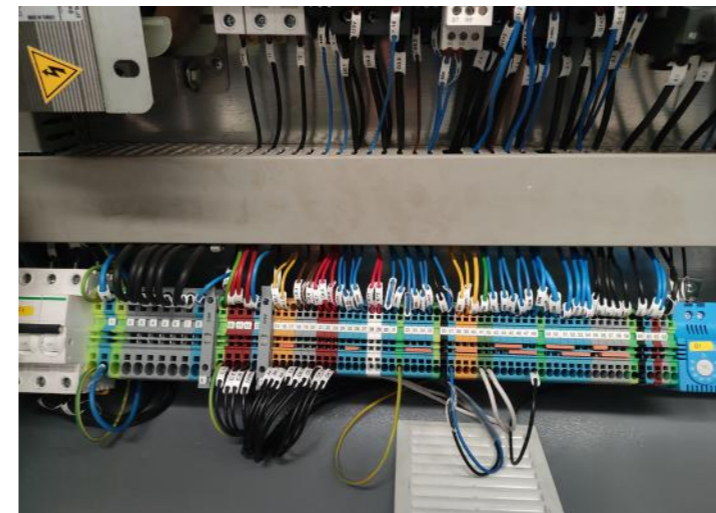

# CMAK Crane Kit

This innovative crane-kit program contains everything required for a crane except the beam(s). Kit programs have also proven to be reliable and cost-effective when prompt delivery is critical.

## STANDARD COMPONENTS

1. Hoist
2. Beam (Girder)
3. End truck carriages (ETC)
4. Hoist power towing arm
5. Crane power towing arm
6. Festoon System with C-Profile
7. Long-travel drives
8. Push-button pendant
9. Bridge control Panel

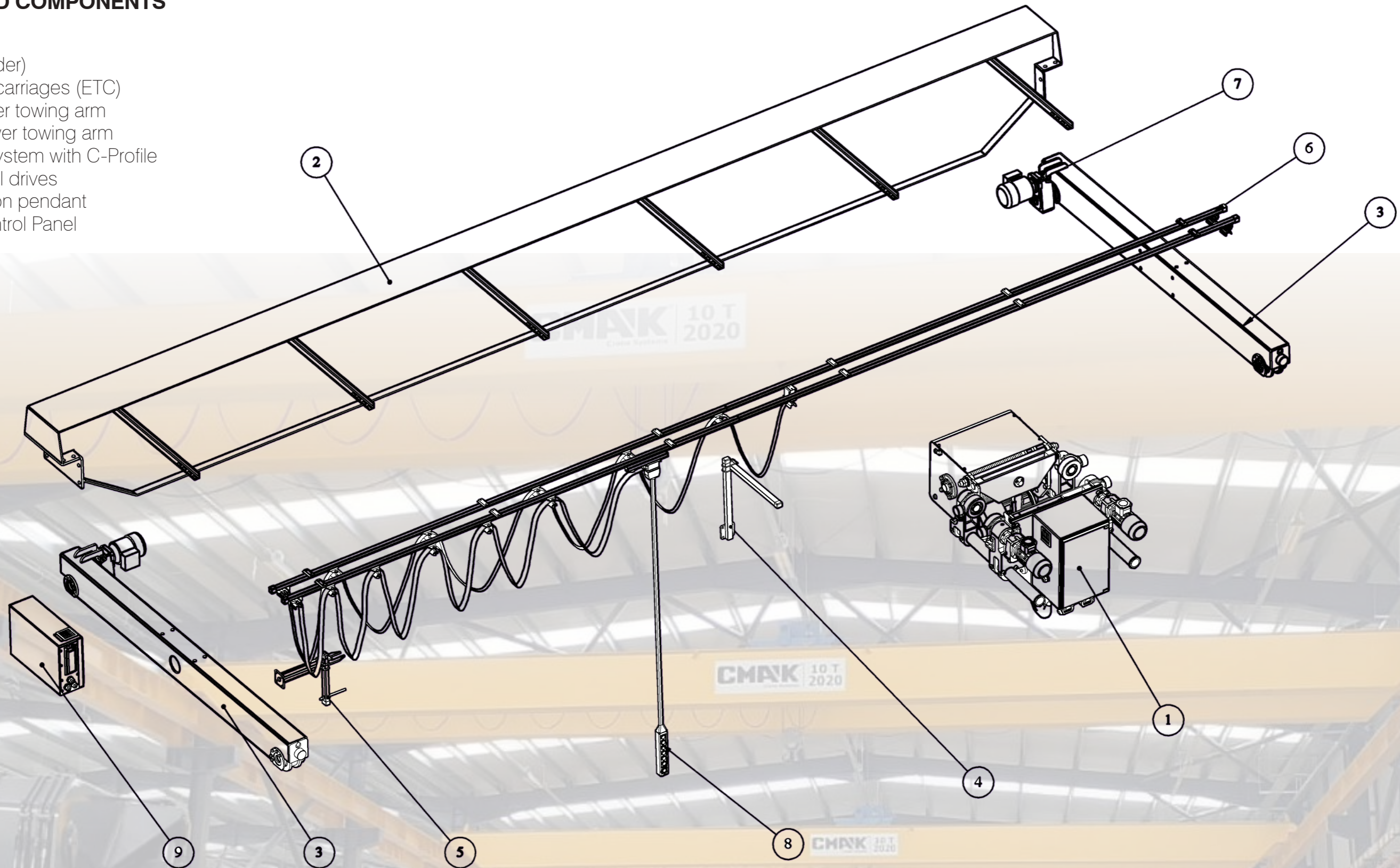

# End Truck Carriages, Wheel Blocks, and Travel Systems

- CMAK end truck carriage and long travel systems are produced with high-tech geometrical controls.
- End truck carriages are designed and produced in FEM classifications, to meet the required duty.
- All trolleys have direct drive systems.
- Lifetime lubricated bearings.
- Trolleys are in standard double speed driven by frequency inverters
- F class isolation and IP55 protection.
- Modular and easy installation with socket connections.
- Heavy Duty.
- Natural Rubber bumpers.
- Suitable plates for end truck carriage assembly (side/top/top&side).
- Top running / Under running type.
- Compact wheel blocks up to Ø400mm wheel.
- GGG70 Graphite Cast Iron Wheels.



## PVC Enclosed Busbar

CMAK Enclosed Busbar systems provide easily assembled, robust, problem-free, and modular power system for cranes and moving machines.



# The World's Most Sophisticated Crane Configurator



Generating bids and formal proposals have never been this easy. Create in minutes a fully calculated quote complete with general arrangement drawings and much more.

## Features

- Create commercial & technical offers.
- Use your own logo.
- Get pdf or spreadsheet outputs.
- Construction calculators.
- General arrangement drawing.
- Duty Cycle calculator (FEM 9.755).
- File sharing system.
- Cloud Based.
- Built-in CRM system.
- 3D models.
- Welding Schemes.
- CNC Cutter files.

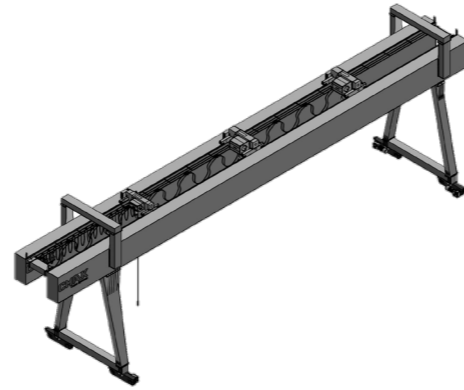

## Load data according to EN 1991-3

